

Turmdrehkran 34 K

Tower Crane / Grue à tour / Gru a torre
Grúa torre / Guindaste de torre

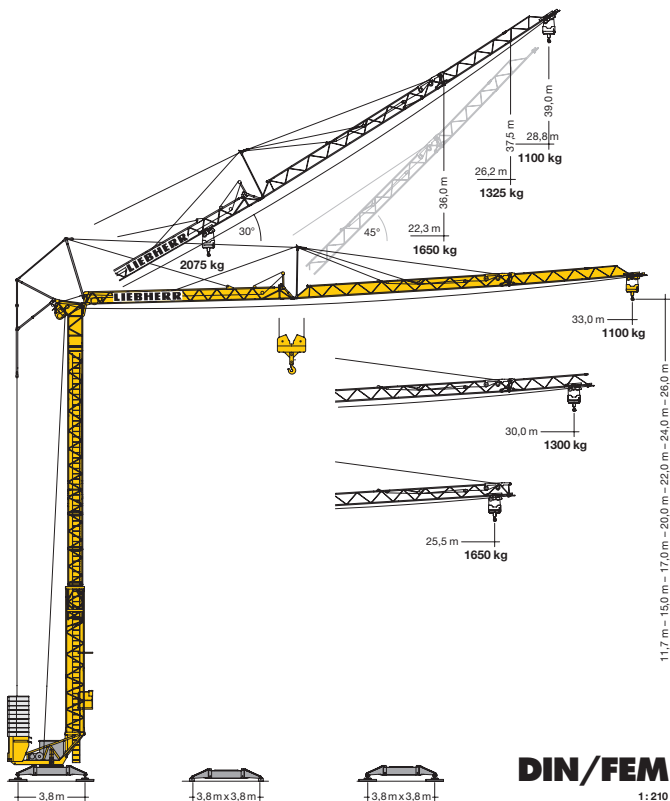

LIEBHERR

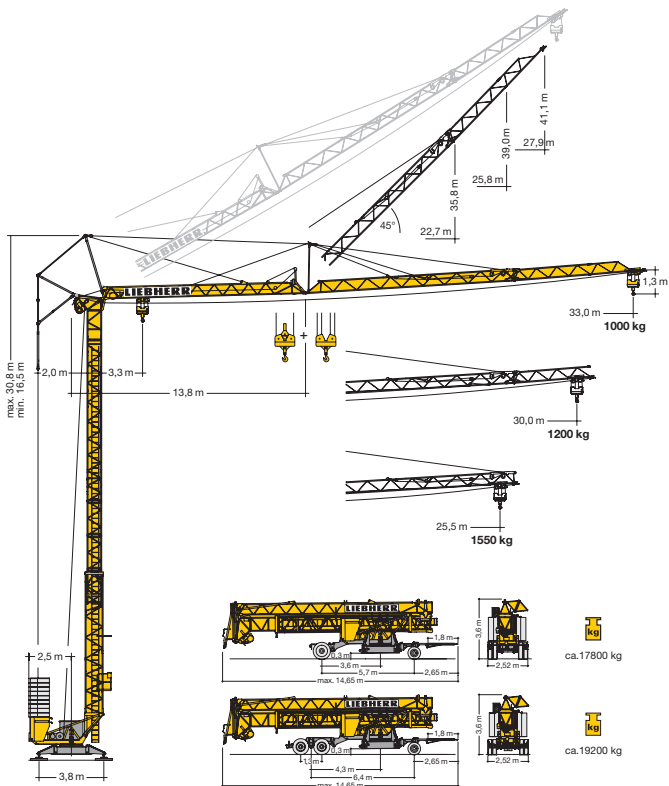

Gewicht

Weight / Poids / Peso / Peso / Pesos



$r = 2,5 \text{ m}$





18980 kg













ca. 10400 kg
(26 m: + 1050 kg)





Ausladung und Tragfähigkeit

Radius and capacity / Portée et charge / Sbraccio e portata / Alcances y cargas / Alcance e capacidade de carga

m	max. kg		m/kg																							
			10,0	11,0	12,0	13,0	14,0	15,0	16,0	17,0	18,0	19,0	20,0	21,0	22,0	23,0	24,0	25,5	26,0	27,0	28,0	29,0	30,0	31,0	32,0	33,0
33,0	3,3 - 17,40 2075		2075	2075	2075	2075	2075	2075	2075	2075	1990	1870	1750	1650	1560	1480	1410	1310	1275	1220	1160	1120	1100	1100	1100	1100
30,0	3,3 - 18,40 2075		2075	2075	2075	2075	2075	2075	2075	2075	2075	2000	1880	1770	1680	1590	1510	1400	1370	1310	1300	1300	1300	1300	1300	1300
25,5	3,3 - 19,50 2075		2075	2075	2075	2075	2075	2075	2075	2075	2075	2010	1890	1790	1700	1650	1650									





m	max. kg		m/kg																							
			10,0	11,0	12,0	13,0	14,0	15,0	16,0	17,0	18,0	19,0	20,0	21,0	22,0	23,0	24,0	25,5	26,0	27,0	28,0	29,0	30,0	31,0	32,0	33,0
33,0	3,3 - 17,06 2000		2000	2000	2000	2000	2000	2000	2000	2000	2000	1870	1750	1640	1740	1450	1370	1300	1200	1170	1110	1060	1010	1000	1000	1000
30,0	3,3 - 18,10 2000		2000	2000	2000	2000	2000	2000	2000	2000	2000	1880	1770	1660	1560	1480	1400	1300	1270	1210	1200	1200	1200	1200	1200	1200
25,5	3,3 - 19,19 2000		2000	2000	2000	2000	2000	2000	2000	2000	2000	2000	1900	1790	1690	1600	1550	1550								





m	max. kg		m/kg																							
			10,0	11,0	12,0	13,0	14,0	15,0	16,0	17,0	18,0	19,0	20,0	21,0	22,0	23,0	24,0	25,5	26,0	27,0	28,0	29,0	30,0	31,0	32,0	33,0
33,0	3,3 - 9,91 4000		3950	3490	3120	2820	2570	2350	2170	2100	2000	2000	1890	1780	1680	1590	1510	1400	1360	1300	1240	1180	1130	1090	1040	1000
30,0	3,3 - 10,46 4000		4000	3750	3350	3030	2760	2530	2400	2400	2280	2130	2000	1880	1780	1680	1590	1510	1440	1370	1310	1250	1200	1200	1200	1200
25,5	3,3 - 11,04 4000		4000	4000	3600	3250	3100	2990	2760	2560	2390	2230	2100	1970	1860	1760	1670	1550								



m	max. kg		Auslegerstellung 30° / Elevated jib 30° / Flèche inclinée 30° m/kg Braccio inclinato a 30° / Pluma inclinada 30° / Lança inclinada 30°																							
			16,0	17,0	18,0	19,0	20,0	21,0	22,3	23,0	24,0	25,0	26,2	27,0	28,0	28,8										
33,0	3,0 - 16,48 2075		2075	2000	1850	1730	1620	1520	1400	1350	1280	1210	1140	1100	1100	1100	1100	1100	1100	1100	1100	1100	1100	1100	1100	1100
30,0	3,0 - 17,15 2075		2075	2075	1950	1820	1710	1600	1480	1430	1350	1325	1325													
25,5	3,0 - 17,76 2075		2075	2075	2040	1910	1790	1680	1650																	

Antriebe

Driving units / Mécanismes d'entraînement / Azionamenti / Mecanismos / Mecanismos

	0 ↔ 0,9 sl./min tr./min	2,2 kW EDC
	20,0 / 40,0 m/min	1,3 / 2,3 kW
	25,0 m/min	2 x 1,3 kW
	0 - 45° ca. 30 sec.	2,2 kW

	Stufe / Step / Cran Marcia / Velocidad Velocidade	kg	m/min
	1	2075	6,0
	2	2075	25,0
	3	1075	50,0
	1	2000 4000	6,0 3,0
	2	2000 4000	25,0 12,5
	3	1000 2000	50,0 25,0
	1	2000 4000	3,0 1,5
	2	2000 4000	30,0 15,0
	3	1500 3000	40,0 20,0
	4	1000 2000	55,0 27,5

BGL	 C.0.08.0040	 +  C.0.08.035,5
-----	---	--

	400 V	Hz	kVA
78,0 m	4 x 6 mm ² KL 4 x 6 mm ² FU	50	22,0 KL 17,0 FU

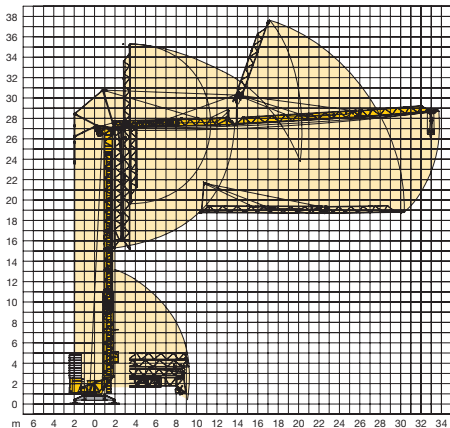

Kolli-Liste

Packing List / Liste de colisage / Lista dei colli / Lista de contenido / Lista de embalagem

Pos. Item	Anz. Qty.		L (m)	B (m)	H (m)	kg		
1	3	Turnstück / Tower section Élément de mât / Elemento di torre Tramo de torre / Peça de torre			2,10	0,85	0,88	350
2	1	Ausleger-Verlängerung 25,5 m – 30,0 m Jib extension / Rallonge de la flèche Elemento estensione braccio Prolongación de pluma / Extensão da lança			4,70	0,80	0,70	180
3	1	Ausleger-Verlängerung 30,0 m – 33,0 m Jib extension / Rallonge de la flèche Elemento estensione braccio Prolongación de pluma / Extensão da lança			3,10	0,80	0,70	65
4	1	Transportachse vorne Tra 100 KY 2 Road transport axle front / Essieux de transport avant / Asse di trasporto anteriore / Eje delantero para transporte / Eixo de transporte dianteiro			3,00	1,13	0,97	660
5	1	Transportachse hinten Tra 120 GY 1A Road transport axle behind / Essieux de transport arrière / Asse di trasporto posteriore / Eje trasero para transporte / Eixo de transporte traseiro			1,90	2,50	1,05	1150
6	1	Transportachse Tra 200 GZ 3 / Road transport axle Essieux de transport / Assali par trasporto Tra 200 GZ 3 / Eje de transporte Eixo de transporte			3,10	2,50	1,10	2600
7	1	Kiste mit Seilen und Kleinteilen / Case with ropes and small parts Caisse avec câbles et pièces détachées / Cassa con funi e accessori Caja con cables y piezas sueltas / Caixa contendo cabos e acessórios			1,00	0,80	1,00	450

Konstruktionsänderungen vorbehalten!
 Subject to alterations! / Sous réserves de modifications!
 Si fa riserva di modifiche! / Salvo modificación da construação!
 ¡Sujeto a modificaciones!

Sämtliche Angaben erfolgen ohne Gewähr. / This information is supplied without liability.
 Ces renseignements sont sans garantie. / Le indicazioni contenute si intendono salvo errori ed omissioni.
 Declinamos toda responsabilidad derivada de la información proporcionada. / Declinamos qualquer responsabilidade quanto à informação fornecida.