



**Narrow profile, lithium  
powered skid steer loader.**

**ELISE<sup>100</sup>**

first.green

Fully **electric**,  
effortlessly portable\*  
and powerful.



\*Possibility of towing by a standard vehicle.

Cost **effective,**  
nearly no  
maintenance.

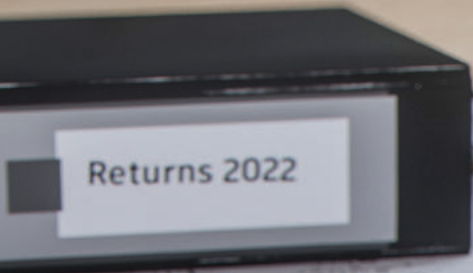

# Powered with technology.

Elise 700 is a lighter version of the Elise 900 skid steer loader, thanks to a lithium battery and narrower profile.



Battery capacity

**280** Ah

Full charge in  
under 5 hours

Hinge pin height

**3627** mm

346mm higher reach than the  
competing average

Total width

**1700** mm

Ease of transport,  
improved mobility



Lighter, narrower and surprisingly powerful

Delivery on demand

Minimal maintenance

100% eco-friendly drive

Lithium battery and narrower profile

Fits to a basic personal vehicle tow trailer

Chassis clearance

**210** mm

Allows off-road capabilities  
while still highly portable

Remote control

**50** m

15 m with  
smart app

Number of charging cycles

**3000+**

Low level of degradation  
with high performance

# Technical specs.



## GENERAL SPECIFICATIONS

Rated load capacity	700 kg
Tipping load	1 400 kg
Minimum travel speed	0.15 km/h
Maximum speed	12 km/h
Maximum travel speed	12 km/h

## MOTOR

Electric engine type	3xGEW
Rated power	3x10 kW
Maximum power	3x27 kW
Maximum torque	3x160 Nm

## TUNE-UP YOUR MACHINE

### Options

- Windowless cabin re-build set
- Air conditioning
- Hard-mounted display
- Android smartphone with control app
- Safety open door sensor
- Wheels for smooth surfaces, Universal wheels or Heavy terrain wheels
- Electric heater

### Standard features

- LiFePO 4 battery with 280 Ah capacity
- Rear-view camera
- Left and right rear-view mirror
- Mandatory lighting
- Front work light
- Rear work lights
- Orange beacon light
- Reversing alarm
- Safety opening window
- Front roller sunshade
- Windshield wiper with sprayer
- Safety reinforced cab
- Seat with safety belt and operator detector system
- Quick coupler – SAE J2513
- ISO joysticks, H Pattern, Reverse H
- Vertical bucket stabilization system
- Cable set pre-install for electric attachments
- External battery charger
- User and maintenance manual

Compare technical specifications for this product online at [first.green](#)



*ELISE*100

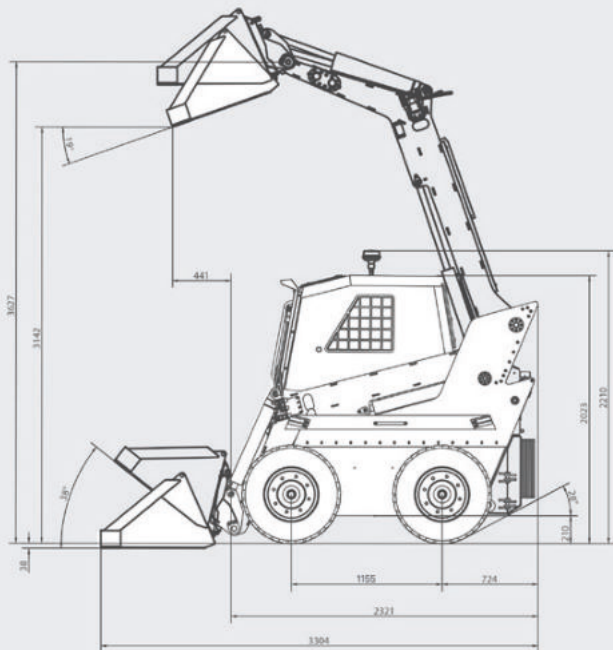

#### WEIGHTS

Rated operating weight 2 800 kg

Total weight of the loader 3 500 kg

#### HYDRAULICS

Hydraulic oil pressure 180 Bar

Hydraulic oil flow 65 l/min

Hydraulic oil reservoir 40 l

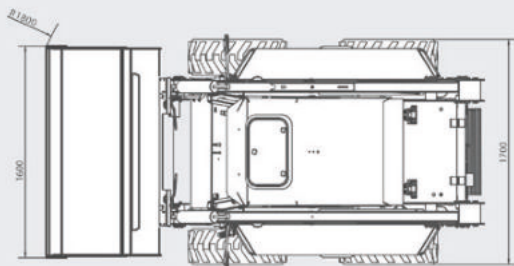



Maintenance



Logistics



Construction



Contractors / Rentals



Agriculture



# With a wide range of attachments.



Standard bucket



Concrete mixer



Pallet forks



Hammer



Auger

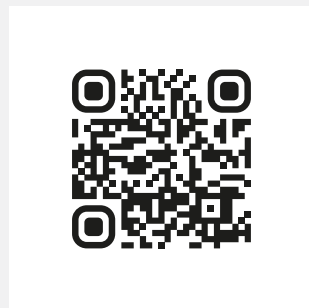

... plus 34 other attachments  
on [first.green](https://www.first.green)



For more FIRSTGREEN products, visit  
**first.green**

+420 737 633 733, [info@first.green](mailto:info@first.green)